

**WENBAO**
温宝球阀 WENBAO BALL VALVE
 OUR PHILOSOPHY IS SIMPLY TO SUPPLY THE BEST
 WENBAO QUALITY ACHIEVEMENT FOR FUTURE

1PC Flanged Ball Valve



Material

ITEM	DESIGNATION	MATERIAL
1	BODY	304/316/WCB
2	CAP	304/316/WCB
3	SEAT	PTFE
4	BALL	304/316
5	STEM	304/316
6	THRUST WASHER	PTFE
7	PACKING	PTFE
8	GLAND	304
9	HADLE	304
10	SPRING WASHER	304
11	STEM NUT	304
12	PLASTIC COVER	PLASTIC

FEATURES:

- NOMINAL PRESSURE:1.6~4.0MPA
- TEMPERATRURE RANGE:-20℃~232℃~350℃
- SUITABLE MEDIUM: WATE, OIL, AIR AND SOME CORROSIVE LIQUID
- BLOW-OUT PROOF STEM/FULL PORT
- INVESTMENT CASTING BODY
- 1000PSI (PN63) W. O. G
- LOCKING DEVICE

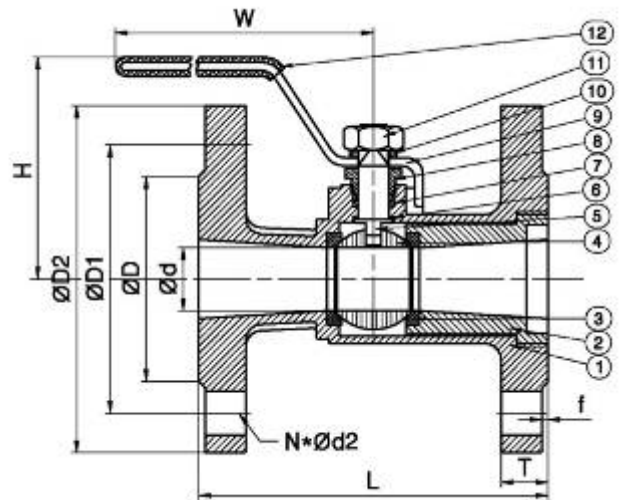

Dimension

SIZE	1/2"	3/4"	1"	1-1/4"	1-1/2"	2"	2-1/2"	3"	4"
ITEM									
d	10.3	13	17	22	25	32	40	50	64
D	46	56	65	76	84	99	118	132	156
D1	65	75	85	100	110	125	145	160	190
D2	95	105	115	140	150	165	185	200	235
T	14	14	15	16	18	18	21	24	24
f	2	2	2	2	3	3	3	3	3
L	92	105	110	125	135	155	170	200	230
W	125	135	135	147	180	180	200	230	240
H	65	75	87	90	95	110	120	130	150
N	4	4	4	4	4	4	8	8	8
d2	14	14	14	18	18	18	18	18	22