

**WENBAO**
**温宝球阀 WENBAO BALL VALVE**  
 OUR PHILOSOPHY IS SIMPLY TO SUPPLY THE BEST  
 WENBAO QUALITY ACHIEVEMENT FOR FUTURE

## 2PC Flanged Ball Valve

## Material



ITEM	DESIGNATION	MATERIAL
1	CAP	304/316/WCB
2	NUT	304
3	BLOT	304
4	GASKET	PTFE
5	BALL	304/316
6	BODY	304/316/WCB
7	SEAT	PTFE
8	STEM	304/316
9	THRUST WASHER	PTFE
10	PACKING	PTFE
11	GLAND	304
12	GLAND BOLT	304
13	HADLE	304
14	STOPPER	304
15	SNAP RING	304

### FEATURES:

- FACE TO FACE DIMENSIONS: ANSI B16.10
- END FLANGED IMENSIONS: ANSI B16.5
- DESIGN: ANSI 16.34
- TEST: API 598
- INVESTMENT CASTING BODY
- LEVER OPERATED OR GEAR OPERATED
- MATERIAL: CARBON STEEL/SCPH2/WCB  
STAINLESS STEEL/304/SCS13  
STAINLESS STEEL/316/SCS14

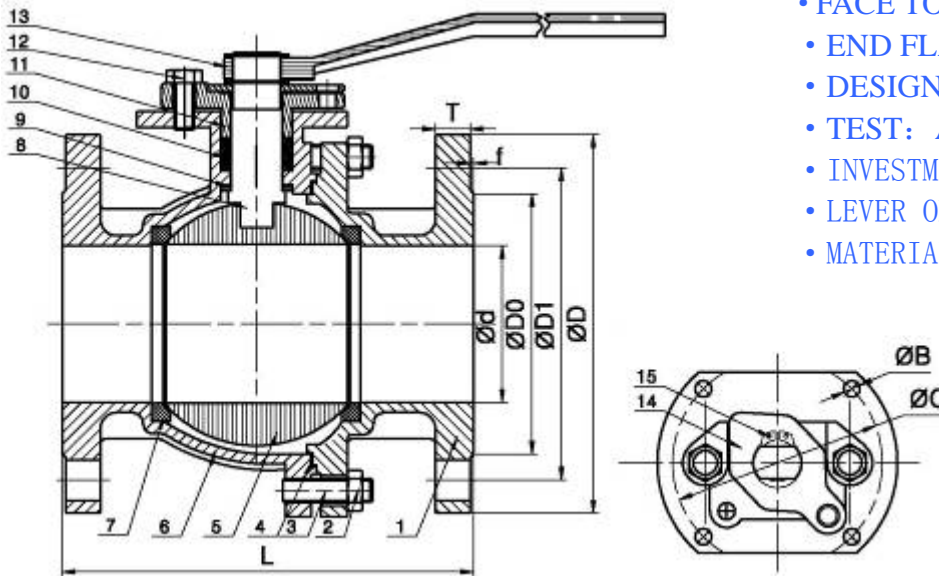

## Dimension

SIZE	1/2"	3/4"	1"	1-1/4"	1-1/2"	2"	2-1/2"	3"	4"	5"	6"	8"	10"
ITEM													
d	15	20	25	32	38	50	64	77	100	125	150	200	250
D	86	95	105	117	124	148	173	186	224	254	279	343	406
D0	61	70	80	89	99	121	140	153	191	218	241	298.5	362.0
D1	37	44	53	65	74	93	105	128	158	186	216	270	324
T	10	11	12	13	15	16	18	19	24	24	26	29	31
f	1.6	1.6	1.6	1.6	1.6	1.6	1.6	1.6	1.6	1.6	1.6	1.6	1.6
L	109	117.5	127.5	140	163.5	178	189.5	202	228.5	356	394	457	533
W	140	140	165	165	195	240	240	260	320				
H	87	88	94.5	100	104.5	116.5	141.5	145.5	170.5				
N*M	4*15	4*15	4*15	4*15	4*15	4*19	4*19	4*19	8*19	8*22	8*22	8*22	8*25
B	5	5	5	5	6.5	6.5	8.5	8.5	8.5				
C	42	42	50	50	70	70	102	102	102				