



**WENBAO**

**温宝球阀 WENBAO BALL VALVE**  
 OUR PHILOSOPHY IS SIMPLY TO SUPPLY THE BEST  
 WENBAO QUALITY ACHIEVEMENT FOR FUTURE

## JIS 2PC Flanged Ball Valve with mounting pad

## Material



ITEM	DESIGNATION	MATERIAL
1	BODY	304/316/WCB
2	SEAT	PTFE
3	BALL	304/316
4	BOLT	304
5	GASKET	PTFE
6	NUT	304
7	CAP	304/316/WCB
8	STEM	304/316
9	THRUST WASHER	PTFE
10	PACKING	PTFE
11	GLAND	304
12	STEM NUT	304
13	HADLE	304

### FEATURES:

- FACE TO FACE DIMENSIONS: JIS 2002-2000
- END FLANGED DIMENSIONS: JIS B2212-1999
- DESIGN: ANSI 16.34
- TEST: GB/T13927-1992
- INVESTMENT CASTING BODY
- LEVER OPERATED WITH EIRECT

### MOUNTING PAD

Shell(by water)	2.4MPa	
Seat	By water	1.5Mpa
	By air	0.6Mpa
Working temperatuer	≅150°	
Suitable medium	Oil,gas,water,other	

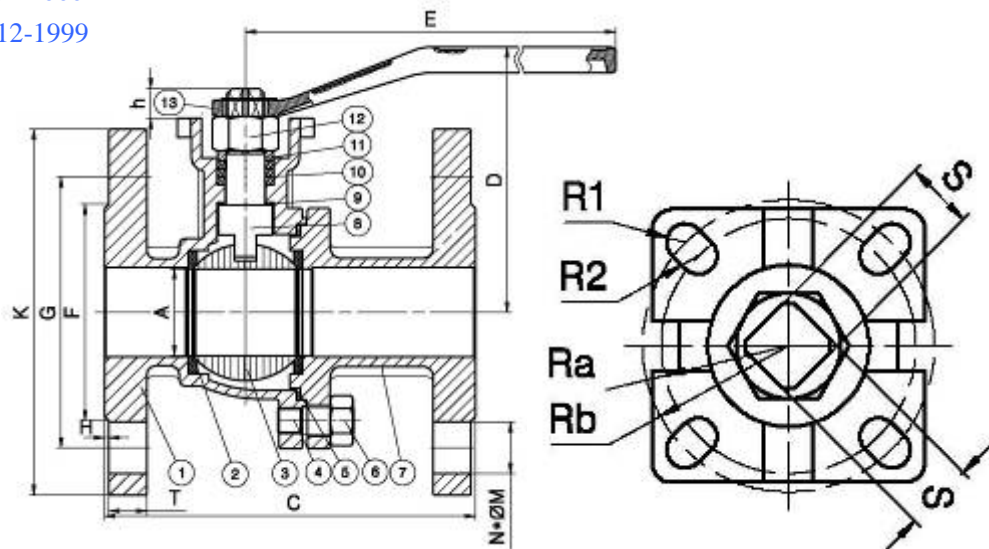

## Dimension

SIZE	1/2"	3/4"	1"	1-1/4"	1-1/2"	2"	2-1/2"	3"	4"
ITEM									
A	15	18	24	32	36	50	62	78	100
F	48.8	54	66	77	85	96	116	126	151
G	70	75	90	100	105	120	140	150	175
K	95	100	125	135	140	155	175	185	210
T	11	13	13	14	14	14	16	16	16
H	1	1	1	2	2	2	2	2	2
C	107	117	127	137	165	177	188.5	203.5	228
D	73	76	86	91	119	127	136	164	178
E	140	140	165	165	195	195	240	260	320
h	9	9	11	11	14	14	14	17	19
N*M	4*15	4*15	4*19	4*19	4*19	4*19	4*19	8*19	8*19
Ra	18	18	21	21	25	25	25	35	35
Rb	21	21	25	25	35	35	35	51	51
R2	3	3	3	3	3.5	3.5	3.5	4.5	4.5
R1	3	3	3.5	3.5	4.5	4.5	4.5	5.5	5.5
S	9	9	11	11	14	14	14	17	19