

**WENBAO**
**温宝球阀 WENBAO BALL VALVE**  
 OUR PHILOSOPHY IS SIMPLY TO SUPPLY THE BEST  
 WENBAO QUALITY ACHIEVEMENT FOR FUTURE

### 3 Pc flanged ball valve

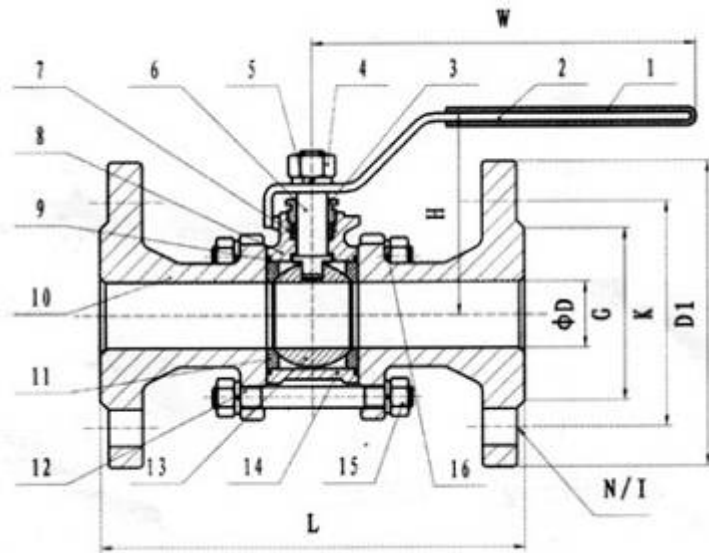

### Material

ITEM	DESIGNATION	MATERIAL
1	PLASTIC COVER	PLASTIC
2	HANDLE	304
3	GLAND NUT	304
4	STEM NUT	304
5	THRUST WASHER	304
6	STEM	304/316
7	STEM PACKING	PTFE
8	BODY	304/316/WCB
9	BODY SEAL	PTFE
10	CAP	304/316/WCB
11	BALL SEAT	PTFE
12	BOLT	304
13	BALL	304/316
14	BODY	304/316/WCB
15	NUT	304
16	THRUST WASHER	304

#### FEATURES:

- FACE TO FACE DIMENSIONS: DIN3202-F1
- END FLAND DIMENSIONS: PN16/PN40 DIN2633
- TEMPERATURE RANGE: -20°C ~ 232°C
- SUITABLE MEDIUM: WATER, OIL, AIR AND SOME CORROSIVE LIQUID
- INVESTMENT CASTING BODY
- DESIGN: 1/2"-2" PN40, 2-1/2"-4" PN16
- TEST: API598
- MATERIAL: CARBON BSTEEL WCB/1.0619  
STAINLESS STEEL 304/1.4308  
STAINLESS STEEL 316/1.4408

### Dimension

ITEM SIZE	D	H	W	PN	DIN PN16					DIN PN40				
				L	D1	K	G	B	1/N	D1	K	G	B	1/N
1/2"	15	79	160	130	95	65	45	14	14/4	95	65	45	16	14/4
3/4"	20	84	160	150	105	75	58	16	14/4	105	75	58	18	14/4
1"	25	100	185	152	115	85	68	16	14/4	115	85	68	18	14/4
1-1/4"	32	105	185	180	140	100	78	16	18/4	140	100	78	18	18/4
1-1/2"	40	115	220	193.5	150	110	88	16	18/4	150	110	88	18	18/4
2"	50	124	220	225	165	125	102	18	18/4	165	125	102	20	18/4
2-1/2"	65	165	305	290	185	145	122	18	18/4	185	145	122	22	18/8
3"	80	177	305	292	200	160	138	20	18/8	200	160	138	24	18/8
4"	94	203	330	350	220	180	158	20	18/8	235	190	162	24	22/8